

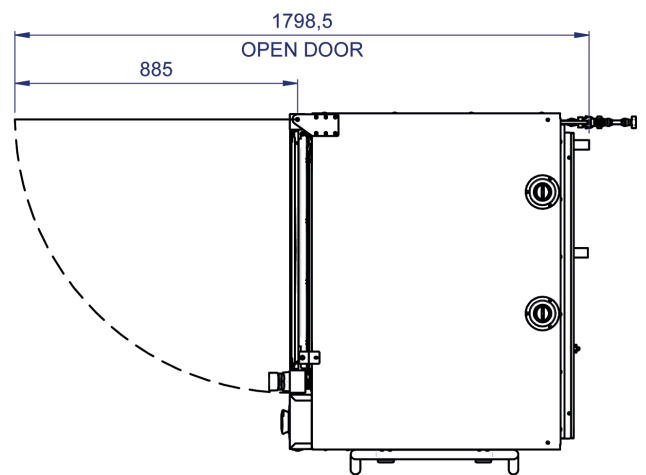

DT16TCCH

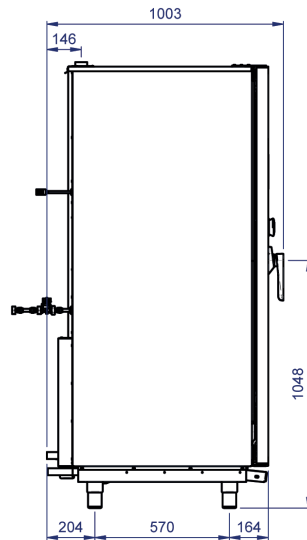
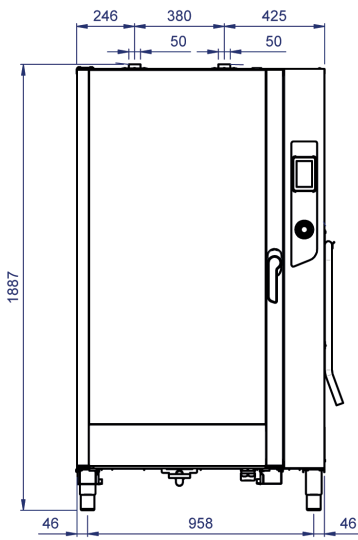

FUNCTIONAL CHARACTERISTICS

Display	5" CAPACITIVE TOUCH
Supply	ELECTRIC
Timer	-
Number of motors	4
Motor speeds	2
Max cooking temperature (°C)	260°C
Core probe	Single point PT1000
Cooking chamber material	AISI304
Opening door	Right handle
Chimney	50 mm Motorized valve

STANDARDS

Certification	CE
---------------	----

TRAYS

Trays rack	Trolley PA 16/80
Max tray load	4 kg

DIMENSIONS

Oven size with handle WxDxH (mm)	1051 X 1002 X 1900
Oven size without handle WxDxH (mm)	1051 X 938 X 1900
Chamber size WxDxH (mm)	700 X 481 X 1496
Unit weight (Kg)	250

PACKAGING

Packaging	PALLET + CARTON BOX
Packaging size WxDxH (mm)	1150 X 1100 X 2050
Unit weight with packaging (Kg)	273
Crate packaging size (optional)	1020 X 970 X 1370

ELECTRICAL DATA

Heaters 6,75kW 50Hz Single power supply

Power	28,1kW
Frequency	50Hz
Power supply standard	380-415V 3N~
Amperage standard	43,9A
Power cord req. standard	5G10

Heaters 6,75kW 50Hz Double power supply	
Power	28,1kW
Frequency	50Hz
Power supply optional	380-415V 3N~/220-240V 3~
Amperage optional	43,9A / 71,9A
Power cord req. optional	5G10/ 4G25
Heaters 6,75kW 60Hz Single power supply	
Power	28,7kW
Frequency	60Hz
Power supply standard	380-415V 3N~
Amperage standard	46,5A
Power cord req. standard	5G10
Heaters 6,75kW 60Hz Double power supply	
Power	28,7kW
Frequency	60Hz
Power supply optional	380-415V 3N~/220-240V 3~
Amperage optional	46,5A / 74,1A
Power cord req. optional	5G10/ 4G25
Heaters 5kW 50Hz	
Power	25,7kW
Frequency	50Hz
Power supply	440V 3~
Amperage	36,7A
Power cord req.	4G10
Heaters 5kW 60Hz	
Power	26,2kW
Frequency	60Hz
Power supply	440V 3~
Amperage	39,3A
Power cord req.	4GX10
WATER CONNECTION REQUIREMENTS	
Humidification Water inlet	3/4" GAS

Washing water inlet	10mm quick fitting
Water drain	2 x 30 mm
Max water hardness	5°f
Water pressure requirement min-max	150-200 kPa
CONSUMPTION	
Humidification Water	16,7l/h max consumption
Rinse Water @2barG	35,5l
Short Washing Water @2barG	66,6l
Long Washing Water @2barG	139l
Short Washing Detergent *	468,8g
Long Washing Detergent *	669,7g
CONNECTIVITY	
USB	2.0
Bluetooth	-
Wi-Fi	-
Cloud	-
ACCESSORIES	
Self clean system kit	-
Oven stand	-
Hood (Air)	-
Hood (Water)	POSLMWF1 POSLMWF2
Core probe	-
Sous Vide core probe	-
Proofer	-
Stacking kit for 2 ovens	-
Smoker	SMK02
Blast chiller	-
Blast chiller stacking kit	-
Water softner cover	WS10
Water softner 6800L	WS11
Water softner 12000L	WS12
Water pressure adapter	WPA
Water shower kit	S1
Detergent 6KG (only with self clean system)	DT2
Detergent 10KG (only with self clean system)	DT4